

JBC

www.jbctools.com

PROGRAMMERS GUIDE



Communication Protocol for Automated Processes

Control Units

UCR245, UCR 470, ALE, NAE, DDE,
DME and HDE

This manual corresponds to the following references:

- **UCR245:**

- **UCR245-5A** (100-230 V)

- **UCR470:**

- **UCR470-5A** (100-230 V)

- **ALE:**

Without solder wire perforation:

- **ALE-9..UA** (100 V)

- **ALE-1..UA** (120 V)

- **ALE-2..UA** (230 V)

With solder wire perforation:

- **ALE-9..UVA** (100 V)

- **ALE-1..UVA** (120 V)

- **ALE-2..UVA** (230 V)

- **NAE:**

- **NAE-9C** (100 V)

- **NAE-1C** (120 V)

- **NAE-2C** (230 V)

- **DDE:**

- **DDE-9C** (100 V)

- **DDE-1C** (120 V)

- **DDE-2C** (230 V)

- **DME:**

- **DME-9C** (100 V)

- **DME-1C** (120 V)

- **DME-2C** (230 V)

- **HDE:**

- **DME-9A** (100 V)

- **DME-1A** (120 V)

- **DME-2A** (230 V)

Communication Protocol

Communication protocol was developed to help you set up the communication between soldering stations and a robot (PC or PLC).

It can be applied to the following JBC's control units:

- **UCR** Control Unit for Robot
- **ALE** Automatic-Feed Soldering Control Unit
- **NAE** 2-Tool Control Unit
- **DDE** 2-Tool Control Unit
- **DME** 4-Tool Control Unit
- **HDE** Heavy Duty Control Unit

The protocol is divided into three layers:

- **PHL**: Physical layer
- **DLL**: Data link layer
- **APL**: Application layer (depends on station model)

Physical Layer (PHL) for UCR

- **UCR** Control Unit for Robot can be connected to a PLC using a five-pin Communications Cable (Ref. 0020261).
- Serial communication type is RS-232, configured as 19200 bps, eight (8) data bits, no (N) parity bit and one (1) stop bit (19200-8N1).
- The communication connector provides "switch" input.
- For a proper connection, it is necessary to connect only 3 cables to the corresponding 3 pins at a typical DB9 male connector (PLC or computer).



Communications Connector

Communications Cable

Ref. 0020261

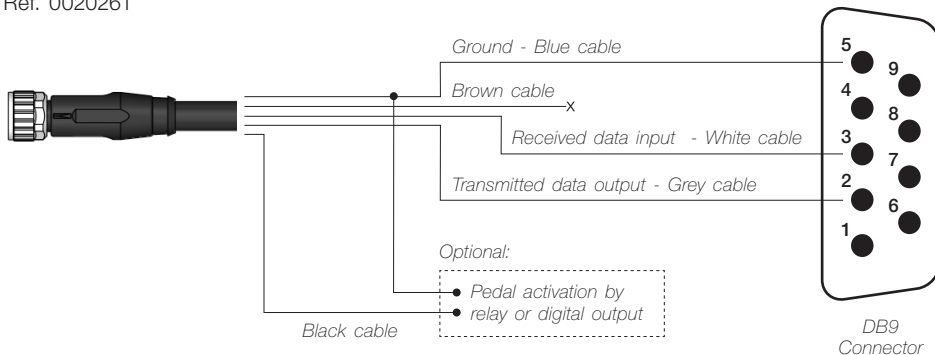

Communications Connector

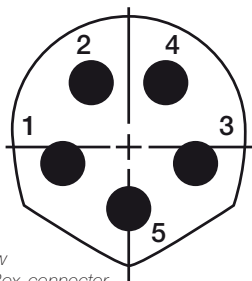

Front view
Control Box connector

| Pin distribution | | |
|------------------|-------|---|
| Pin | Color | Description |
| 1 | Brown | Not used |
| 2 | White | Serial input: RS232 RX |
| 3 | Blue | Common reference: GND for RS232 and pedal |
| 4 | Black | Switch input: 0V or 24V to start feeding. Leave it open to stop. |
| 5 | Grey | Serial output: RS232 TX |

Switch input activates the Control Box, using a relay or transistor digital output. Digital output from the PLC to the switch input can be PNP or NPN style, as well as a relay contact.

Physical Layer (PHL) for ALE, NAE, DDE, DME and HDE Control Units

- JBC control units can be connected to a PLC by a RJ12 direct cable (ref. 0019751) and DB9-RJ12 Adapter (ref. 0015383).
- Serial communication type is RS-232, configured as 19200 bps, eight (8) data bits, no (N) parity bit and one (1) stop bit (19200-8N1).

Robot Station Connector

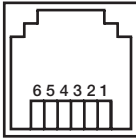

Female RJ12
Connector

| Pin distribution | |
|------------------|-----------------------------|
| Pin | Description |
| 1 | Not used |
| 2 | Common reference: RS232 GND |
| 3 | Serial input: RS232 RX |
| 4 | Serial output: RS232 TX |
| 5 | Common reference: RS232 GND |
| 6 | Not used |

Data Link Layer (DLL) *Applies to all*

The frame format is shown in the tables below. By factory settings, communications are made with addresses. They can be disabled using W-SAD command. Depending on the command used, the Data field* is not necessary.

With no address

| Start | Control Header* | Control Command | Data* | Stop | Check |
|--------|--------------------|-----------------|--------------------|--------|--------|
| 1 byte | 1 byte | 3 bytes | 0 or 5 bytes | 1 byte | 1 byte |
| STX | `R', `W', `A', `N` | "code" | "-9999" to "99999" | ETX | BCC |

With address (factory default)

| Start | Source Address | Target Address | Control Header* | Control Command | Data* | Stop | Check |
|--------|----------------|----------------|--------------------|-----------------|--------------------|--------|--------|
| 1 byte | 2 bytes | 2 bytes | 1 byte | 3 bytes | 0 or 5 bytes | 1 byte | 1 byte |
| STX | "00" to "99" | "00" to "99" | `R', `W', `A', `N` | "code" | "-9999" to "99999" | ETX | BCC |

*Info

| Control Header Field* | | Data Field |
|------------------------------|-----------------------------|-------------|
| R (Read) | | Is not used |
| W (Write) | | Used |
| A (Acknowledgement) | Response to Reading Comands | Used |
| | Response to Writing Comands | Is not used |
| N (Negative Acknowledgement) | | Used |

Frame Fields

| | |
|------------------------|---|
| Start | Start of transmission. Corresponds to the character STX of ASCII code (0x02). |
| Source Address | The Source Address range is from "00" to "99". The factory setting for Robot Address is "00". |
| Target Address | The Target Address range is from "00" to "99". Factory settings for JBC devices are as follows: <ul style="list-style-type: none"> · Soldering Stations Address is "01" · Solder Feeder Address is "10" · Fume Extractor Address is "20" |
| Control Header | Four Codes are used (see table from page 5). |
| Control Command | Select the command to be used (see pages 11-29). |
| Data | Composed of five digits. First tens of thousand is sent and thereafter successively until the last unit. Example: in order to send "12345" it is first sent "1", and finally "5". If it is a negative number, the minus sign is at the tens of thousands digit, shown as an ASCII character "-". Example: In order to send "-50", the data will be sent is "-0050". If the number has less than five digits, then zeros will be placed before. Example: in order to send "375" the data will be sent is "00375". |
| Stop | End of transmission. Corresponds to the ASCII code character ETX (0x03). |
| Check | This is an error Check Field. The value is obtained by calculating the logic function XOR for the whole frame, excluding the BCC. |

Frame Reception

The Robot sends a Command Frame to the JBC device. This information is sent to the Application Layer (APL). The Command Frame obtained from the robot is correct if it has the correct length and **“starts with STX + finishes with ETX + correct BCC”**.

The JBC device will send a Response Frame. In the case of a Response Frame with errors, the Robot determines the number of consecutive Command Frames that will send to the JBC device. If the Robot receives a Response Frame with errors, it cannot be resent by the JBC device.

The JBC device does not expect ACK/NAK from the Robot.

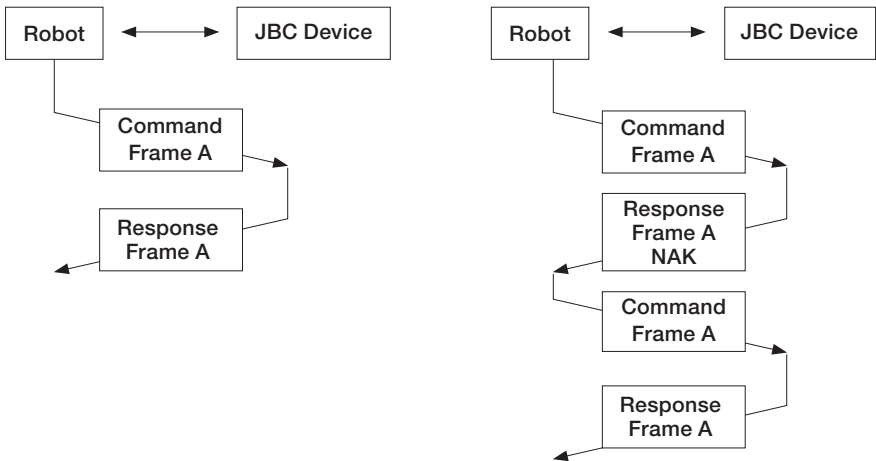

Application Layer (APL)

The robot starts the communication with a Command Frame and the JBC device sends a Response Frame. For a detailed functional description, see the tables with the command overview starting on page 11.

- Temperature is always shown in °C.
- The power is given in thousands of the theoretical maximum JBC Device power [%] without decimals.

Tools:

| Number | Description |
|--------|---------------|
| 0 | Without tool |
| 1 | T210 |
| 2 | T245/T470 |
| 2 | TR245/TR470 |
| 3 | PA120/AM120 |
| 4 | HT420/AT420 |
| 5 | DS360 |
| 6 | DR560 |
| 7 | NT115 |
| 8 | NP115/AN115 |
| 9 | TRA245/TRA470 |

Ports:

| Number | Description |
|--------|-------------|
| 1 | Port 1 |
| 2 | Port 2 |
| 3 | Port 3 |
| 4 | Port 4 |

Station Errors:

| Number | Description |
|--------|------------------------------|
| 00000 | OK |
| 00001 | Stop due by overload (TRAFO) |
| 00002 | Temperature sensor error |
| 00003 | Memory |
| 00004 | Mains frequency |
| 00005 | JBC device model |
| 00006 | Not connected MCU tools |
| 00007 | Warning overload (TRAFO) |

Port Errors:

| Number | Description |
|--------|---|
| 00000 | OK |
| 00001 | Short-circuit |
| 00002 | Short-circuit non-recoverable, JBC Device should be restarted |
| 00003 | Open circuit |
| 00004 | No tool |
| 00005 | No tool accepted |
| 00006 | Tool detection |
| 00007 | Stop due by maximum powers (not implemented) |
| 00008 | Stop due by overload (MOS) |
| 00009 | Warning overload (MOS) |

Communication Errors:

| Number | Description |
|--------|---|
| 00001 | BCC error (frame error when doing the sum check) |
| 00002 | Format error (format is not correct, i.e. incorrect size) |
| 00003 | Out of range (modified value out of limit) |
| 00004 | Control error (control code not accepted) |
| 00005 | Robot Control Mode Error (in JBC Device Menu is "off" for "Robot Mode" selected) |
| 00006 | Station model error (station unknown) |
| 99999 | Undefined (error not defined) |

**Tool Operating Status:
(Standard Processes)**

| Number | Description |
|--------|--|
| 00000 | Working |
| 00001 | Stand, it still has not gone into sleep mode (delay) |
| 00002 | Sleep* |
| 00003 | Hibernation* |

**Not selectable with W-PSx commands.*

**Tool Operating Status:
(Automated Processes)**

| Number | Description |
|--------|-------------|
| 00000 | Working |
| 00010 | Cooling |

Suction Status:

| Number | Description |
|--------|-----------------|
| 00000 | Desoldering OFF |
| 00100 | Desoldering ON |

Motor Status:

| Number | Description |
|--------|--|
| 00000 | Motor OFF |
| 01000 | Motor ON and forward motion (dispensing) |
| 02000 | Motor ON and backward motion |

The following diagram shows the soldering stations work flow:

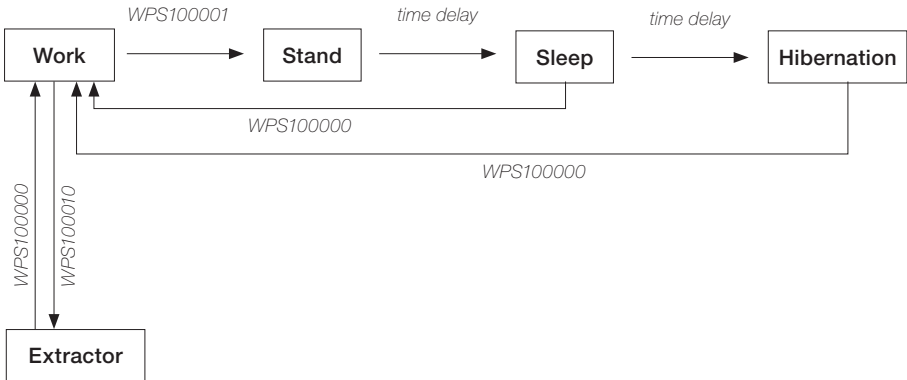

Commands

| Code | Description | Details |
|--------------|--------------------------------|---|
| W-PSx | Write - Port Status + port | <p>Sets the Tool Operating Status.</p> <p>Replace the 'x' with the number of the destination port in ASCII, for example "WPS1".</p> <p>The Data Field contains the selected Operating Status for the tool.</p> <p>Send "00000" for Working, "00010" for Extractor (stand by) or "00001" for Stand.</p> <p>The Tool Operating Status is managed by the robot. Except sleep and hipermantion mode, whose status are reached after time delay. See page 10 for more information.</p> <p>The JBC device answers with an "A-PSx" (example "APS1").</p> |
| R-PSx | Read - Port Status + port | <p>To get the Tool Operating Status.</p> <p>See page 10 for identifier information.</p> <p>The 'x' must be replaced with the number of the destination port in ACCII, for example "RPS1".</p> <p>The Data Field contains the tool operating status.</p> <p>The JBC device respons with an "A-PSx".</p> |
| W-STx | Write - Select Temp. + port | <p>Sets the Tip Working Temperature.</p> <p>Replace the 'x' with the number of the destination port in ASCII, for example "WST1".</p> <p>The Data Field contains the selected temperature, expressed in °C. The temperature modification must be done in steps of 5 degrees.</p> <p>The JBC device responds with an "A-STx", for expamle "AST1".</p> <p>Warning: selected temperature is a volatile setting, therefore use the W-NVS frame in order to save it into the station memory.</p> |

| Code | Description | Details |
|--------------|----------------------------|---|
| R-STx | Read - Select Temp. + port | <p>To get the set Working Temperature.</p> <p>Replace the 'x' with the number of the destination port in ASCII, for example "RST1".</p> <p>The JBC device responds with an "A-STx".</p> <p>The Data Field contains the current Working Temperature, expressed in °C , for example "AST100350".</p> |
| R-TTx | Read - Tip Temp. + port | <p>To get the current Tip Temperature.</p> <p>The 'x' must be replaced with the number of the destination port in ASCII (example "RTT1").</p> <p>The JBC device responds with an "A-TTx" and the Data Field contains the current tip temperature expressed in °C, example "ATT100183".</p> |
| R-PPx | Read - Port Power + port | <p>To get the current power delivered to the tip.</p> <p>The 'x' must be replaced with the number of the destination port in ASCII (example "RPP1").</p> <p>The Data Field contains the delivered power expressed in %, for example "APP100840" for 84%.</p> <p>The JBC device response with A-PPx.</p> |

| Code | Description | Details |
|--------------|---|--|
| W-Axy | Write - Adjust Temperature + port + tool | <p>Sets a temperature offset. Used when a tool temperature fine-adjustment is needed.</p> <p>The 'x' must be replaced with the number of the destination port and the "y" with the tool number in ACCII, for example "WA12", for port 1 and tool TR245. See page 8 for identifier information.</p> <p>The Data field contains the Adjustment Temperature for the tool, expressed in °C. The maximum adjustment temp is +/- 50°C, for example "WA1200012". The temperature offset must be done in steps of 1 degree.</p> <p>Note: In order to send -50 °C, the data will be sent is "-0050".</p> <p>The JBC device answers with an "A-Axy".</p> |
| R-Axy | Read - Adjust Temperature + port + tool | <p>To get the Tool Adjustment Temperature.</p> <p>The 'x' must be replaced with the number of the destination port and the "y" with the tool number in ACCII, for example "RA12" for port 1 and tool TR245. See page 8 for identifier information.</p> <p>The JBC device answers with an "A-Axy".</p> <p>The Data Field contains the Tool Adjustment Temperature, expressed in °C.</p> |
| W-MAT | Write - Maximum Temperature | <p>Set the Maximum Temperature selectable with W-STx.</p> <p>The Data Field contains the Maximum Work Temperature, expressed in °C</p> <p>The JBC device responds with an "A-MAT".</p> |

| Code | Description | Details |
|--------------|---|---|
| R-MAT | Read - Maximum Temperature | <p>To get the Maximum Temperature selectable With W-STx.</p> <p>The JBC device responds with an "A-MAT".</p> <p>The Data Field contains the Maximum Working Temperature, expressed in °C.</p> |
| W-MIT | Write - Minimum temperature | <p>Set the Minimum Temperature selectable with W-STx.</p> <p>The Data Field contains the Minimum Work Temperature, expressed in °C.</p> <p>The JBC device responds with an "A-MIT"</p> |
| R-MIT | Read - Minimum temperature | <p>To get the Minimum Temperature selectable with W-STx.</p> <p>The JBC device responds with an "A-MIT".</p> <p>The Data Field contains the Minimum Work Temperature, expressed in °C.</p> |
| W-Sxy | Write - Sleep Temperature + port + tool | <p>Sets the Sleep Temperature.</p> <p>The 'x' must be replaced with the number of the destination port and the "y" with the tool number* in ACCII, for example "WS12", for port 1 and tool TR245.</p> <p>See page 8 for identifier information.</p> <p>The Sleep Temperature must be done in steps of 5 degrees.</p> <p>The data Field contains the Sleep Temperature for the tool, expressed in °C.</p> <p>The JBC device answers with an "A-Sxy".</p> |

| Code | Description | Details |
|--------------|---|---|
| R-Sxy | Read - Sleep Temperature + port + tool | <p>To get the Sleep Temperature.</p> <p>The 'x' must be replaced with the number of the destination port and the "y" with the tool number in ACCII, for example "RS12", for port 1 and tool TR245. See page 8 for identifier information.</p> <p>The JBC device answers with an "A-Sxy".</p> <p>The Data Field contains the Sleep Temperature, expressed in °C.</p> |
| W-Dxy | Write - Sleep Delay + port + tool | <p>Sets the Sleep Delay Time.</p> <p>The 'x' must be replaced with the number of the destination port and the "y" with the tool number* in ACCII, for example "WD12", for port 1 and tool TR245. See page 8 for identifier information.</p> <p>The data Field contains the delay time, to enter into sleep since the command W-PSx-00001 is received. The Sleep Delay must be set in steps of 1 minute with a range from 0 to 9.</p> <p>To disable the sleep mode, send "99999".</p> <p>The JBC device answers with an "A-Dxy".</p> |
| R-Dxy | Read - Sleep delay + port + tool | <p>To get the Sleep Delay Time.</p> <p>The 'x' must be replaced with the number of the destination port and the "y" with the tool number" in ACCII, for example "RD12", for port 1 and tool TR245. See page 8 for identifier information.</p> <p>The JBC device answers with an "A-Dxy".</p> <p>The Data Field contains the current Sleep Delay Time, expressed in minutes.</p> <p>If get answered "99999", the sleep mode is disabled.</p> |

| Code | Description | Details |
|---------------------|--|--|
| <p>W-Hxy</p> | <p>Write - Hibernation Delay + port + tool</p> | <p>Sets the Hibernation Delay Time.</p> <p>The 'x' must be replaced with the number of the destination port and the "y" with the tool number* in ACCII, for example "WH12", for port 1 and tool TR245. See page 8 for identifier information.</p> <p>The Data Field contains the delay time to enter into Hibernation since the Sleep Tool Operating Status is reached. The Hibernation Delay must be set in steps of 5 minutes with a range from 0 to 60 minutes.</p> <p>The Data Field contains the current Hibernation Delay Time, expressed in minutes.</p> <p>To disable the Hibernation mode, send "99999".</p> <p>The JBC device answers with an "A-Hxy".</p> |
| <p>R-Hxy</p> | <p>Read - Hibernation Delay + port + tool</p> | <p>To get the Hibernation Delay Time.</p> <p>The 'x' must be replaced with the number of the destination port and the "y" with the tool number* in ACCII, for example "RH12", for port 1 and tool TR245. See page 8 for identifier information.</p> <p>The JBC device answers with an "A-Hxy".</p> <p>The Data Field contains the Hibernation Delay Time, expressed in minutes.</p> <p>If get answered "99999", the Hibernation Mode is disabled.</p> |

| Code | Description | Details |
|--------------|---|--|
| R-EDx | Read - enter delay time (sleep/ hibernation) + port | <p>To get the remaining delay time before enter into sleep or hibernation mode.</p> <p>The 'x' must be replaced with the number of the destination port in ACCII, for example "RED1".</p> <p>The JBC device answers with an "A-EDx".</p> <p>The Data Field contains the remaing time, expressed in seconds.</p> |
| R-TT | Read - Transformer Temperature | <p>To get the Power Supply Temperature.</p> <p>The JBC device responds with an "A-TT".</p> <p>The Data Field contains the Transformer Temperature, expressed in °C.</p> |
| R-QTx | Read - Transistor Temp. + port | <p>To get the current Transistor Temperature.</p> <p>The 'x' must be replaced with the number of the destination port in ACCII, for example "RQT1".</p> <p>The JBC device answers with an "A-QTx".</p> <p>The Data Field contains the current Transistor Temperature, expressed in °C.</p> |
| W-HAx | Write - Higher Temp Alarm + port | <p>Sets the upper Temperature Alarm limit.</p> <p>The 'x' must be replaced with the number of the destination port in ASCII, for example, "WHA1".</p> <p>The data Field contains the upper Temperature Alarm limit, epressed in °C. The temperature modification must be done in steps of 5 degrees.</p> <p>The JBC device responds with an "A-HAx".</p> |

| Code | Description | Details |
|--------------|-------------------------------------|---|
| R-HAx | Read - Higher Temp. Alarm + port | <p>To get the Upper Temperature Alarm limit.</p> <p>The 'x' must be replaced with the number of the destination port in ACCII, for example "RHA1".</p> <p>The JBC device answers with an "A-HAx".</p> <p>The Data Field contains the upper Temperature Alarm limit, expressed in °C.</p> |
| W-LAx | Write - Lower Temp Alarm + port | <p>Sets the lower Temperature Alarm limit.</p> <p>The 'x' must be replaced with the number of the destination port in ASCII, for example, "WLA1".</p> <p>The Data Field contains the Lower Temperature Alarm limit, expressed in °C. The temperature modification must be done in steps of 5 degrees.</p> <p>The JBC device responds with an "A-LAx".</p> |
| R-LAx | Read - Lower Temp Alarm + port | <p>To get the Lower Temperature Alarm limit.</p> <p>Replace the 'x' with the number of the destination port in ASCII, for example, "RLA1".</p> <p>The JBC device responds with an "A-LAx".</p> <p>The Data Field contains the lower Temperature Alarm limit, expressed in °C.</p> |

| Code | Description | Details |
|--------------|-----------------------------------|---|
| W-HDx | Write - Higher Delay Alarm + port | <p>Sets the delay time to activate the Upper Temperature Alarm. The delay time starts when the tip temperature is above the value in HAx.</p> <p>Replace the 'x' with the number of the destination port in ASCII, for example "WHD1".</p> <p>The Data Field contains the delay time to activate the Upper Temperature Alarm, expressed in seconds and hundreds of seconds, according to: Format "ss.cc" in ASCII. "ss" corresponds to the time in seconds, and "cc" corresponds to the time in hundreds of a second. Example: "01.60" means 1,6s; "00.10" means 0.1s.</p> <p>The JBC device responds with an "A-HDx".</p> <p>To disable the Hibernation mode, send "99999".</p> |
| R-HDx | Read - Higher Delay Alarm + port | <p>To get the delay time to activate the Upper Temperature Alarm.</p> <p>Replace the 'x' with the number of the destination port in ASCII, for example "RHD1".</p> <p>The Data Field contains the delay time to activate the Upper Temperature Alarm, expressed in seconds and hundreds of seconds, according to: "Format "ss.cc" in ASCII. "ss" corresponds to the time in seconds, and "cc" corresponds to the time in hundredths of a second. Example: "01.60" means 1,6s; "00.10" means 0,1s. When the tip temperature is above the Upper Temperature Alarm for a longer time than the delay set in the HDx, the Alarm will be set to 1."</p> <p>The Data Field contains the Higher Delay Alarm.</p> <p>"99999" means that the alarm is disabled.</p> |

| Code | Description | Details |
|--------------|----------------------------------|---|
| W-LDx | Write - Lower Delay Alarm + port | <p>Sets the delay time to activate the Lower Temperature Alarm.</p> <p>The delay time is counted, when the temperature falls below the “Lower Temperature Alarm” limit; previously defined with LAX.</p> <p>Replace the ‘x’ with the number of the destination port in ASCII, for example “WLD1”.</p> <p>The Data Field contains the delay time to activate the “Lower Temperature Alarm”, expressed in seconds and hundredths of seconds, according to: Format “ss.cc” in ASCII. “ss” corresponds to the time in seconds, and “cc” corresponds to the time in hundredths of a second. Example: “01.60” means 1,6s; “00.10” means 0,1s.</p> <p>The JBC device responds with an “A-LDx”.</p> <p>To disable the Hibernation mode, send “99999”.</p> |
| R-LDx | Read - Lower Delay Alarm + port | <p>To get the delay time to activate the Lower Temperature Alarm.</p> <p>When the tip temperature falls down the Lower Temperature Alarm for a longer time than the delay set in the W-Lax, the Alarm will be set to 10.</p> <p>Replace the ‘x’ with the number of the destination port in ASCII, for example “RLD1”.</p> <p>The Data Field contains the delay time to activate the “Lower Temperature Alarm”, expressed in seconds and hundredths of seconds, according to: Format “ss.cc” in ASCII. “ss” corresponds to the time in seconds, and “cc” corresponds to the time in hundredths of a second. Example: “01.60” means 1,6s; “00.10” means 0,1s.</p> <p>The JBC device responds with an “A-LDx”</p> <p>“99999” means that the alarm is disabled.</p> |

| Code | Description | Details |
|-------|---------------------------------------|---|
| R-TAx | Read - Temperature Alarm + port | <p>To get the Temperature Alarm indicator.</p> <p>Replace the 'x' with the number of the destination port in ASCII, for example "RTA1".</p> <p>The JBC device responds with an "A-TAx".</p> <p>The Data Field contains the Temperature Alarm value according to: 0 - Alarm disabled 1 - Alarm activated</p> <p>The units digit contains the high temperature alarm (HTA) and the tens digit contains the low temperature alarm (LTA). Example: 00001 = HTA 00010 = LTA 00011 = HTA+LTA</p> <p>'0' means there is no alarm. '1' means the alarm has been previously set to "on".</p> |
| R-SMN | Read - Station Model Name | <p>To get the JBC Device Model Name</p> <p>The JBC device responds with an "A-SMN".</p> <p>The Data Field contains the requested information.</p> |
| R-CTx | Read - Connect Tool + port | <p>To get the Connected Tool. See page 8 for value information.</p> <p>The 'x' must be replaced with the number of the destination port in ASCII, for example "RCT1".</p> <p>The JBC device response with A-CTx.</p> <p>The Data Field contains the identifier of the current connected tool.</p> |

| Code | Description | Details |
|--------------|---|--|
| R-PEx | Read - Port Error + port | <p>To get the Port Error. See page 9 for value information.</p> <p>The 'x' must be replaced with the number of the destination port in ACCII, for example "RPE1".</p> <p>The JBC device answers with an "A-PEx".</p> <p>The Data Field contains the current Port Error. For example "APE100004" for "no tool" error.</p> |
| R-SER | Read - Station Error | <p>To get the JBC Device Error.</p> <p>See page 9 for value information. The JBC device responds with an "A-SER".</p> <p>The Data Field contains the JBC Device Error value.</p> |
| W-RST | Write - Restart Station | <p>To restart the JBC Device.</p> |
| W-RSP | Write - Reset Station Parameters (factory default) | <p>To reset the JBC Device Parameters to the factory default parameters.</p> <p>The JBC device responds with an "A-RSP".</p> |
| R-CPx | Read - Counter Plugged Hours + port | <p>To get the Counter value for "Plugged Hours",</p> <p>Replace the 'x' with the number of the destination port in ASCII, for example "RCP1".</p> <p>The JBC device responds with an "A-CPx"</p> <p>The Data Field contains the Counter value of "Plugged Hours", expressed in hours.</p> |

| Code | Description | Details |
|--------------|---|---|
| R-CNx | Read - Counter No Tool Hours + port | <p>To get the Counter value of “No Tool Hours”</p> <p>Replace the ‘x’ with the number of the destination port in ASCII, for example “RCN1”.</p> <p>The JBC device responds with an “A-CNx”.</p> <p>The Data Field contains the Counter value of “No Tool Hours”, expressed in hours.</p> |
| R-CSx | Read - Counter Sleep Hours + port | <p>To get the Counter value of “Sleep Hours”</p> <p>Replace the ‘x’ with the number of the destination port in ASCII, for example “RCS1”.</p> <p>The JBC device responds with an “A-CSx”.</p> <p>The Data Field contains the Counter value of “Sleep Hours”, expressed in hours.</p> |
| R-CHx | Read - Counter Hibernation Hours + port | <p>To get the Counter value of “Hibernation Hours”.</p> <p>Replace the ‘x’ with the number of the destination port in ASCII, for example “RCH1”.</p> <p>The JBC device responds with an “A-CHx”.</p> <p>The Data Field contains the Counter value of “Hibernation Hours”, expressed in hours.</p> |
| R-CWx | Read - Counter Work Hours + port | <p>To get the Counter value of “Work Hours”.</p> <p>Replace the ‘x’ with the number of the destination port in ASCII, for example “RCW1”.</p> <p>The JBC device responds with an “A-CWx”.</p> <p>The Data Field contains the Counter value of “Work Hours”, expressed in hours.</p> |

| Code | Description | Details |
|--------------|--|---|
| R-CCx | Read - Counter Sleep + port | <p>To get the Counter value of “Sleep Cycles”, means the number of times the tool went into Sleep Mode.</p> <p>The ‘x’ must be replaced with the number of the destination port in ACCII, for example “RCC1”.</p> <p>The JBC device responds with an “ACCx”</p> <p>The Data field contains the number of times the tool went into Sleep Mode.</p> |
| R-CDx | Read - Counter Desold + port | <p>To get the Counter value of “Desoldering Cycles”, means the number of times the desoldering tool has been activated.</p> <p>The ‘x’ must be replaced with the number of the destination port in ACCII, for example “RCC1”.</p> <p>The JBC device responds with an “A-CDx”.</p> <p>The Data field contains the number of times the desoldering tool has been activated.</p> |
| W-NVS | Write - Non-volatile Setting | <p>To save the work temperature selected with W-STx, in the EEPROM memory.</p> <p>The next time the JBC Device starts, this stored temperature will be loaded.</p> <p>The data field must contains “00000”.</p> <p>The JBC device responds with an “A-NVS”.</p> |
| W-SAD | Write new source address / new addressing mode | <p>Forces the station to write a new source address by filling the data field with a value compressed between “00000” and “00099”.</p> <p>If the data field contains “00000”, the station assumes that the protocol is changed to “with-no-address” mode.</p> <p>Warning: Command only available for UCR stations.</p> |

| Code | Description | Details |
|--------------|--|---|
| R-FST | Read - Fuse state | <p>To get the JBC Device Fuse status.</p> <p>The JBC device responds with an "A-FST".</p> <p>The Data Field contains the JBC Device Fuse status value according to:</p> <p>'0' - There is no fuse '1' - There is fuse</p> <p>Warning: Command only available for UCR stations.</p> |
| R-SVR | Read - Software version | <p>To get the JBC Device Software Version.</p> <p>The JBC device responds with an "A-SVR".</p> <p>The Data Field contains the requested information.</p> |
| R-DCx | Read - Counter Dispensed Cycles + port | <p>To read the desoldering counter cycles the 'x' must be replaced with the destination port number in ASCII of the request, for example "RCD3".</p> <p>The equipment answers with an "ACDx" as the control field, in the example "ACD3".</p> <p>Data field will contain the requested information.</p> |
| R-DLx | Read - Counter Dispensed Cycles + port | <p>To read the dispensed length counter the 'x' must be replaced with the destination port number in ASCII of the request, for example "RDL1".</p> <p>The equipment answers with an "ADLx" as the control field, in the example "ADL1".</p> <p>Data field will contain the requested information in hexadecimal. Units [dmm]. Example: 1000 dmm -> Data field = 0x00000003E8</p> |

| Code | Description | Details |
|--------------|---------------------------|--|
| W-IFE | Write - Ignore Fuse Error | <p>To ignore fuse error, allowing the station to continue working.</p> <p>The equipment answers with an "AIFE" as the control field.</p> |
| R-MOD | Read - Mode | <p>To read the station's dispensing mode. The data field will contain the requested information.</p> <p>Mode: '0': Continuous mode '1': Discontinuous mode '2': Program mode '3': Tin reload</p> <p>Example: Continuous -> Data field = 00000</p> |
| W-MOD | Write - Mode | <p>To modify the station's dispensing mode.</p> <p>The equipment answers with an "AMOD" as the control field.</p> |
| R-LEN | Read - Length | <p>To read the station's dispensing length.</p> <p>The equipment answers with an "ALEN" as the control field.</p> <p>The data field will contain the requested information. Units [dmm].</p> <p>Example: 1000 dmm -> Data field = 01000</p> |

| Code | Description | Details |
|-------|--------------------------|--|
| W-LEN | Write - Length | The equipment answers with an "ALEN" as the control field. |
| R-FEE | Read - Dispensing Status | <p>To read the station's dispensing motor status. The equipment answers with an "AFEE" as the control field.</p> <p>The data field will contain whether the station is dispensing.</p> <ul style="list-style-type: none">• '0' dispensing motor stopped• '1' dispensing motor running |
| R-SPD | Read - Speed | <p>To read the station's dispensing speed.</p> <p>The equipment answers with an "ASPD" as the control field.</p> <p>The data field will contain the requested information. Units [dmm/s]. Example: 100 dmm/s -> Data field = 00100</p> |
| W-SPD | Write - Speed | <p>To modify the station's dispensing length.</p> <p>The equipment answers with an "ASPD" as the control field.</p> |
| R-DIA | Read - Diameter | <p>To read the station's soldering wire diameter. The equipment answers with an "ADIA" as the control field.</p> <p>The data field will contain the requested information. Units [cmm]. Example: 100 cmm -> Data field = 00100</p> |

| Code | Description | Details |
|--------------|---------------------------------|--|
| W-DIA | Write - Diameter | To modify the station's soldering wire diameter. The equipment answers with an "ADIA" as the control field. |
| R-BCK | Read - Backward Length | <p>To read the station's backward length. The equipment answers with an "ABCK" as the control field.</p> <p>The data field will contain the requested information. Units [dmm]. Example: 10 dmm -> Data field = 00010</p> |
| W-BCK | Write - Backward Length | <p>To modify the station's backward length.</p> <p>The equipment answers with an "ABCK" as the control field.</p> |
| R-WCD | Read - Wire Clogging Detection | <p>To read the station's wire clogging detection.</p> <p>The equipment answers with an "AWCD" as the control field.</p> <p>The data field will contain the request information.</p> <ul style="list-style-type: none"> • '0' wire clogging detection deactivated • '1' wire clogging detection activated |
| W-WCD | Write - Wire Clogging Detection | <p>To modify the station's wire clogging detection.</p> <p>The equipment answers with an "AWCD" as the control field.</p> |

| Code | Description | Details |
|--------------|-----------------------------|---|
| W-STR | Write - Start Dispensing | To activate the station's dispensing motor. The equipment answers with an "ASTR" as the control field. |
| W-STP | Write - Stop Dispensing | To deactivate the station's dispensing motor. The equipment answers with an "ASTP" as the control field. |

Communication Frame Examples for Soldering Stations

Frame with addresses - Write Maximum Work Temperature Command

Source Address: 00; original Target Address: 01; Command: W-MAT; set Max. Work Temp. to 375°C

| Codification | Start | Source Address | Target Address | Operation Header | Operation Code | Data | Stop | Check |
|--------------|-------|----------------|----------------|------------------|----------------|------------|------|------------|
| ASCII | STX | 00 | 01 | W | MAT | 00375 | ETX | calculated |
| HEX | 02 | 3030 | 3031 | 57 | 4D4154 | 3030333735 | 03 | 3E |

Sending code: 0230303031574D41543030333735033E

Frame without addresses - Write Maximum Work Temperature Command

Command: W-MAT; set Max. Work Temp. to 375 °C / 707 °F

| Codification | Start | Operation Header | Operation Code | Data | Stop | Check |
|--------------|-------|------------------|----------------|------------|------|------------|
| ASCII | STX | W | MAT | 00375 | ETX | calculated |
| HEX | 02 | 57 | 4D4154 | 3030333735 | 03 | 3F |

Sending code: 02574D41543030333735033F

Factory Settings for Control Box

Communication configuration: 19200 - 8N1

General Settings:

With Addresses: Target Address: 01
Source Address: 00

Device Port: 1

Mode/Status: Extract (stand by)

Selected Work Temperature: 350 °C / 662 °F

Sleep Temperature: 150 °C / 302 °F

Sleep Delay Time: 10 sec.

Device Settings:

Max. Temperature: 500 °C / 932 °F

Min. Temperature: 90 °C / 194 °F

Tool Settings:

Upper Temperature Alarm: not set

Lower Temperature Alarm: not set

Adjust Temperature: 0 °C / 32 °F

Sleep Temperature: 150 °C / 302 °F

Sleep Delay Time: 0 sec.

Hibernation Delay Time: 10 sec.



This product should not be thrown in the garbage.
In accordance with the European directive 2012/19/EU, electronic equipment at the end of its life must be collected and returned to an authorized recycling facility.



More information available on our website

www.jbctools.com